

Thermal Pipe Systems, Inc.

VEE-TITE® 230 PIPING SYSTEM

**FOR CONDENSATE AND
LOW TEMPERATURE HOT WATER SERVICE**

SPECIFICATIONS & DRAWINGS

5205 W. WOODMILL DRIVE, SUITE 33
WILMINGTON, DELAWARE 19808
PHONE: 302.999.1588
WWW.THERMALPIPESYSTEMS.COM

VEE-TITE 230 PIPING SYSTEM SPECIFICATIONS

VEE-TITE shall be used where specified for condensate, low temperature hot water, chilled water, or dual temperature line service using a rubber ring joining method. Unless otherwise specified, all pipe, fittings, valves and accessories shall conform to the requirements of ANSI B31.1 and shall be of the proper type for pressure and temperature of the heating or cooling water.

FRP CARRIER PIPE: Carrier Pipe shall be Fiberglass Reinforced Plastic (FRP) and shall be filament wound using epoxy resins. Pipe shall have a resin-rich, reinforced liner and comply with ASTM D2310, D2996, and D5686. Resin Designation Codes shall be RTRP-11FX1: 3110 for all sizes. The pipe shall be of spigot by spigot design and a separate two-ring coupling shall be provided. The coupling shall be made of the same material as the pipe and shall have machined grooves into which the sealing rings are inserted.

RUBBER SEALING RING: The sealing rings shall be molded high temperature (HT) heat resistant Ethylene Propylene Diene Monomer (EPDM) using a properly vulcanized compound. The ring surfaces shall be smooth and free from all porosity and internal voids.

CASING PIPE: The casing shall be [**Polyvinyl Chloride (PVC)**] pipe shall be of virgin PVC resin meeting the minimum classification requirements of ASTM D1784 or extruded, black, [**High Density Polyethylene (HDPE)**] conforming to ASTM D1248 and D3350. The thickness for PVC casing shall be as shown on page three. Consult manufacturer for HDPE dimensional data.

RUBBER END SEALS: Rubber end seals for insulated VEE-TITE shall be a high temperature (HT) heat resistant Ethylene Propylene Diene Monomer (EPDM) molded rubber compound. All surfaces shall be smooth and free of voids.

POLYURETHANE FOAM INSULATION: The insulation shall be Polyurethane Foam and shall meet the following specifications:

Type:	Two component urethane
Compressive Strength:	40 psi parallel min at 5% comp.
Shrinkage:	None at 70°F
Free Rise Density:	2.0 to 3.0 lbs./cubic foot
Aged "K" (70°F - 72 hrs)	0.16 BTU-in./hour-°F-ft.2
Closed Cell Content:	90%

INSULATION CONCENTRICITY: Carrier Pipe shall be concentric to casing pipe. The allowable maximum deviation from centerline of carrier pipe shall be plus or minus 1/4 inch at the casing center point and plus or minus 1/16 inch at the end seals.

CASING-TITE SEAL: The Casing-Tite Seal shall be 30 mil high temperature tape.

FITTINGS: All FRP fittings shall be uninsulated and shall be compression molded or filament wound. All fittings shall be designed to be used with the carrier pipe. Fittings may be configured with spigot ends to match pipe and connect with Vee-Tite couplings or have a bell end with a taper to match a properly tapered spigot end, or a flanged end. Adhesive where required shall meet the requirements of the operating conditions of the system. Fittings shall be un-insulated for encasement in concrete thrust blocks.

FLANGES: All FRP flanges shall be uninsulated and may be compression molded or filament wound. All flanges shall be designed to be used with the carrier pipe and meet ANSI B 16.5 with a 150-pound bolt hole circle and number of bolts. Full-face gaskets 1/8" thick with a durometer rating of 60-70 are recommended.

WALL PENETRATION SLEEVES: Provide where piping passes through walls below and above grade, in floor, or in roof slabs, shall be schedule 40 or standard weight coated black steel pipe or shall be as specified by the Design Engineer. Space between the pipe OD and the sleeve ID shall never be less than 1/2". Sleeves shall be held securely in proper position and location during construction. Sleeves shall be of sufficient length to pass through entire thickness of walls or slabs. Sleeves in floor slabs shall extend 2 inches above the finished floor. Refer to typical detail of wall penetration as shown. In existing concrete manholes or building walls, penetrations may be made using the "core drilling" method providing proper care is taken to drill the holes to the size needed and square to the line of the pipe.

WALL PENETRATION SEALS: All wall penetrations shall be sealed to prevent water from entering the building or manhole. The sealing material shall be specified by the engineer.

VEE-TITE APPLICATION ENGINEERING

PIPE SYSTEM DESIGN: Standard design techniques and practices for VEE-TITE shall be used. Thermal Pipe Systems, Inc. Engineering Department may on request provide certain detailed design aspects of the piping for each project based on the project documents and drawings provided by the Design Engineer. It is understood that the project specifications and layout drawings will specify the type of service, location of the site, temperature and pressure classifications, soil conditions, general path and elevations of the system, location and design of manholes, known obstacles, size of the carrier pipe, and the maximum permissible heat losses. It is further understood that other requirements such as the type of pipe, the location size and capacity of valves, traps, pumps, anchors, controls, expansion devices and

special structural elements will be provided by the Design Engineer. The design provided by Thermal Pipe Systems, Inc. and their engineers for the piping will be in accordance with ANSI B31.1 and good engineering practices.

Fluid flow design will be based on Hazen-Williams formula with "C" Factor of 150, or a variation of the Euler formula for water flow.

INSULATION: Thickness of insulation for VEE-TITE pipe and fittings shall be as shown on page four.

TEMPERATURE AND PRESSURE: The VEE-TITE piping system and all its components are designed to operate up to 150 psig at 230°F plus typical surges.

DIMENSIONS AND WEIGHTS of insulated VEE-TITE piping are as shown on page four. The VEE-TITE piping will be furnished in 20-foot lengths.

PRE-INSULATED VEE-TITE® 230 PIPE

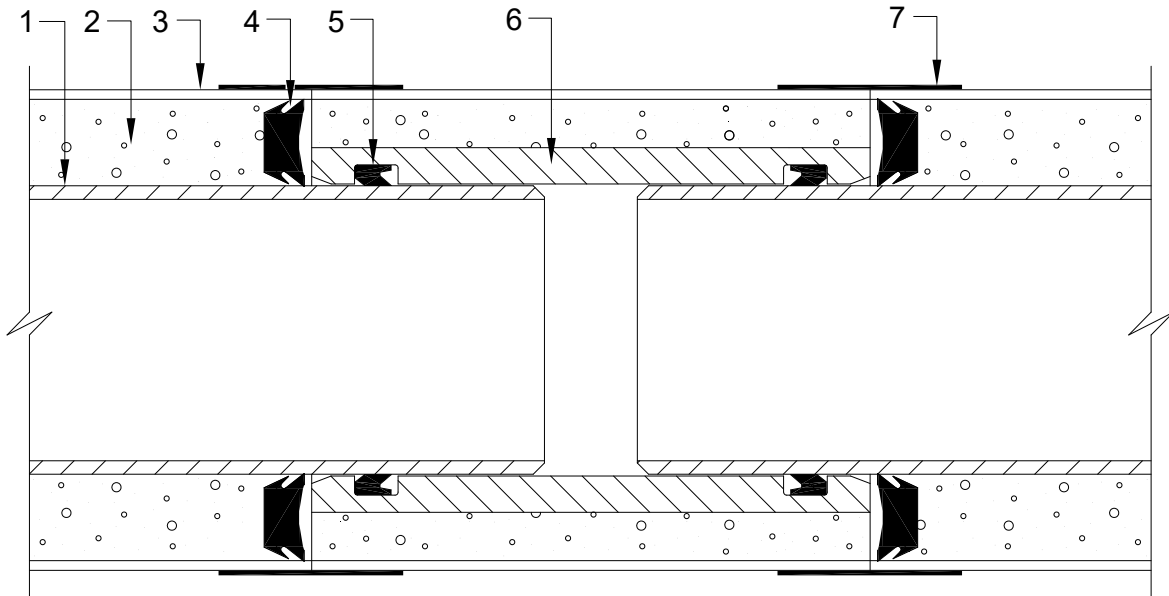

1. CARRIER: FRP Pipe
2. INSULATION: Polyurethane Foam
3. CASING: PVC or HDPE
4. END SEAL: EPDM
5. CARRIER SEALING RING: EPDM
6. COUPLING: Grooved FRP (Preinsulated)
7. CASING-TITE SEAL: 30 mil H.T. Tape

NOM. PIPE SIZE	CARRIER O.D.	CASING O.D.	THICKNESS		WEIGHT (LBS./20 FT.)
			PVC CASING	FOAM	
2	2.38	4.50	.14	0.92	40
3	3.50	6.14	.12	1.20	55
4	4.50	8.16	.16	1.67	89
6	6.63	10.20	.20	1.59	146
8	8.63	12.24	.24	1.57	205
10	10.75	14.28	.28	1.49	288
12	12.75	16.00	.25	1.38	326

NOTE: All dimensions are in inches unless noted. Consult manufacturer for HDPE dimensional data.

PRE-INSULATED VEE-TITE® 230 PIPE

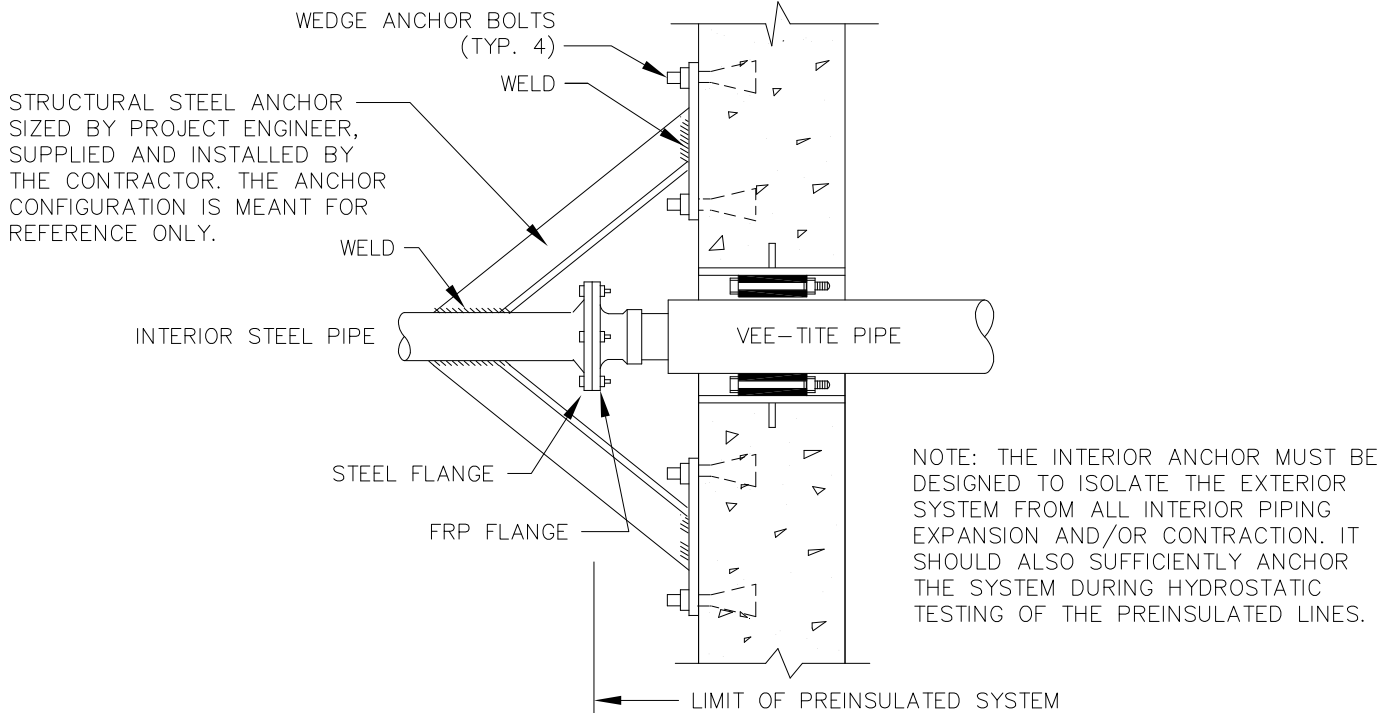

TYPICAL ANCHOR AT WALL PENETRATIONS
NO SCALE

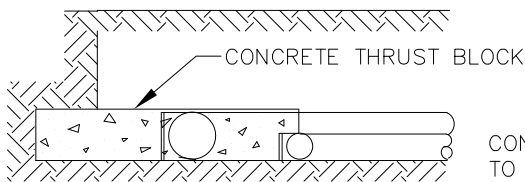

SECTION A-A

CONCRETE THRUST BLOCK TO BEAR AGAINST SOLID UNDISTURBED EARTH OR REPLACED EARTH COMPACTED TO 95% PROCTOR DENSITY.

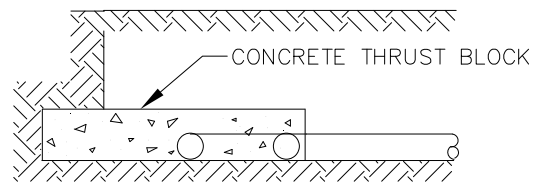

SECTION B-B

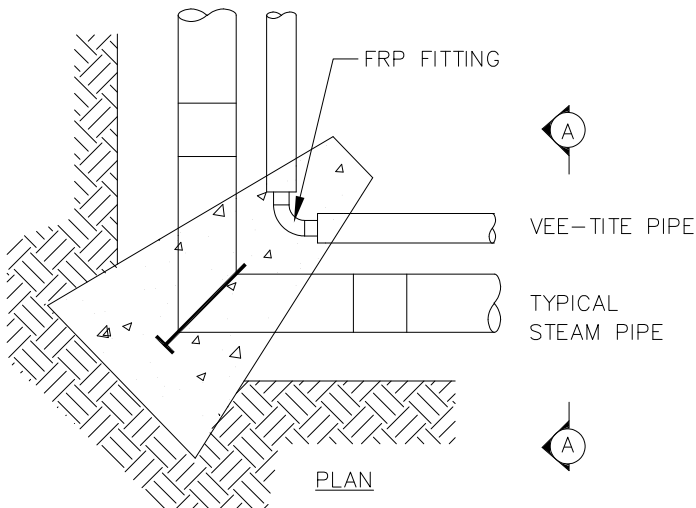

CONDENSATE SERVICE

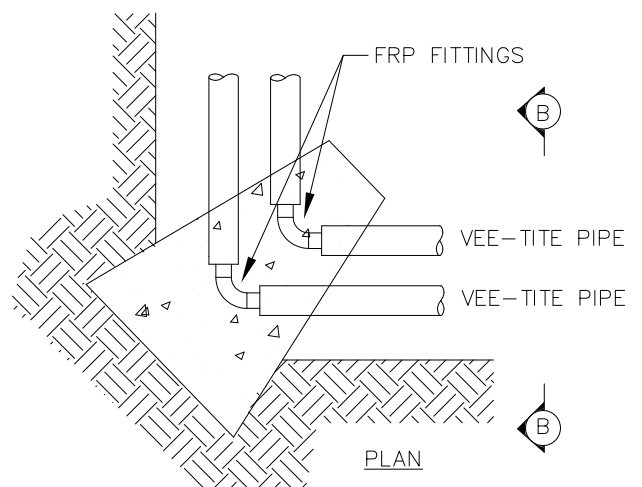

HOT/CHILLED WATER SERVICE

TYPICAL THRUST BLOCK AT ELBOWS
NO SCALE

VEE-TITE INSTALLATION SPECIFICATION

GENERAL: Installation of the VEE-TITE piping system shall be done in accordance with the appropriate publications including ANSI B31.1 and the following specifications and instructions. A Thermal Pipe Systems, Inc. field representative may conduct an installation clinic to pre-qualify contract personnel in the proper procedures for the installation.

Piping shall be accurately cut to dimensions established at the construction site and shall be worked into place without springing or forcing, properly clearing all openings and equipment. Excessive cutting or other weakening of structural members to facilitate piping installation shall not be permitted. Pipe ends shall have burrs removed by reaming and shall be installed to permit free expansion and contraction without damage to joints. Good workmanlike procedures shall be followed.

All piping, unless otherwise indicated, shall be pitched with a grade of not less than 1 inch in 40 feet toward the drain points when applicable.

Open ends of pipe lines and equipment shall be properly capped or plugged during installation to keep dirt or other foreign matter out of the system.

RECEIVING AND HANDLING SHIPMENTS

INSPECTION: Each shipment shall be inspected upon its arrival at the jobsite. The products are carefully loaded at the plant using methods acceptable to the carrier and it is their responsibility to deliver the pipe in good condition. It is the responsibility of the installing contractor to ascertain whether there has been any loss or damage. The carrier is the contractor's agent. Any pipe or equipment that arrives damaged or is lost in shipment shall be reported by the contractor.

Make overall inspection of the load. If load is intact, ordinary inspection while unloading should be enough to make sure that the pipe has arrived in good condition. It is the responsibility of the receiver to make certain that there has been no loss or damage. Note specifically that any end packaging should not show signs of damage. If the load has shifted, or end packing damaged, then each piece must be carefully inspected for damage. Specifically, the ends should be inspected for scars, nicks, etc. Other obvious damage is cause for rejection. Check total quantities of each item against the tally sheet (pipe, fittings, etc.). Any damaged or missing items are to be noted on the delivery receipt and the receipt returned to the carrier. Notify the carrier immediately and make claim in accordance with the carrier's instructions. Thermal Pipe Systems, Inc. will assist, if

necessary, in handling this claim. Do not dispose of damaged material - the carrier will notify you of the procedure to follow.

UNLOADING INSTRUCTIONS: The means by which the pipes are unloaded in the field is the decision and responsibility of the installing contractor. The use of forklift type equipment frequently simplifies and speeds up the unloading of larger sizes and usually provides extra protection against damage in handling. To prevent the possibility of the core pipe from shifting within the casing pipe, do not stand a length on one end or raise it vertically. Under no condition should a pipe be dragged along the ground. Do not lift fittings or pipe by inserting a bar, pipe, etc., inside of the core, damage to the pipe may result. If any pipe is damaged in unloading and handling, mark the damaged area and set it aside. A Thermal Pipe Systems, Inc. representative will determine whether the damaged casing can be repaired in the field and will determine exact method for repair and instruct the contractor in making the repair.

COLD WEATHER HANDLING FOR PVC CASED PIPE: As the temperature approaches and drops below freezing, the flexibility and impact resistance of VEE-TITE piping is reduced. PVC casing becomes hard and brittle in cold weather and will crack more readily if dropped or hit. Therefore, extra care should be used when handling during cold weather. Pipe at the bottom of a stack may become out-of-round due to the weight of material above it. At normal application temperatures, this corrects itself soon after the load is removed. Under freezing conditions, this recovery to full initial roundness may take several hours.

STORAGE: Store pipe on dunnage in a flat area. Support the barrel of the casing evenly. Spigot ends should overhang dunnage. Store random lengths separately where they will be readily available. Individual lengths of pipe should be stacked in piles no higher than 5 feet. It should be noted that when PVC pipe is stored outside and exposed to prolonged periods of sunlight, an obvious discoloration of the pipe can occur. This coloration is a surface layer of hardened plastic and does not inhibit the long-term properties and performance of the pipe. A method of protecting pipe during long exposures (several months) to sunlight is to cover it with canvas or other opaque material. Do not use clear plastic sheets and be sure to provide for air circulation under the sheets.

LOADING TRANSFER TRUCKS: Use trucks with long bodies so that pipe lengths do no overhang. Make certain truck bed is smooth, without cross-strips, bolt heads, or other protrusions that could damage the pipe. Short body trucks may be used if fitted with racks that properly support the pipe in a horizontal position. The rack should have supports spaced every 3 feet or less along the pipe lengths. Pad the contact areas to avoid damage to the pipe.

EXCAVATION: Excavation should consider the need for the thrust blocks at all fittings that are directly buried in the ground. The trench bottom must give uniform support along the entire length of any pipelines. Where several pipelines are in a common trench, the trench must be wide enough to maintain the specified distances between adjacent lines, generally a minimum of 6" in pipe sizes up to 6" diameter, and 12" minimum in sizes 8" and larger. The excavation should be in a straight line except where fittings are located.

TRENCHING: Trenching shall follow the elevations provided by the Design Engineer on the contract drawings. The trench depth should always allow for a minimum cover height of 24" over the top of the casing. Keep excavations free of water during construction. If the contractor determines it is necessary to remove unsuitable material to a depth greater than specified, refill excavations carried below the depths indicated or directed with specified bedding material and compact in 6" lifts to 95% of maximum density in accordance with ASTM D1557, Method D. Excavate and replace soil disturbed and weakened by the contractors operations or soils permitted to soften from exposure to weather, with bedding material and compact with a plate-type vibratory compactor.

TRENCH WIDTHS: The width of the trench at the top of the pipe should be held to the minimum required for efficient and proper installation. The reason for this is to keep the earth load on the pipe as small as possible. The wider the trench at the top of the pipe, the greater the load on the pipe. Note that an increase in trench width above the top of the pipe, by stepping the sides or digging a wider offset trench, does not affect the earth load on the pipe. On the other hand, a trench that is too narrow will make assembly difficult and may reduce the rate and quality of installation. In addition, lack of ample room will limit the capability to properly backfill and tamp around the pipe. Although each job or portion of a job must be considered on an individual basis, as a rule, the following minimum trench widths at the top of the pipe are recommended: Minimum: one foot greater than the outside diameter of the casing. Where two or more pipes are in the same trench, use the distance between outside casing of the outside pipes plus one foot. Maximum: Use above method for minimum plus two feet.

DISTRIBUTING PIPE ALONG TRENCH: Pipe lengths may be strung along the line of the trench to minimize additional handling during installation.

PLACING PIPE IN THE TRENCH: The VEE-TITE pipe may be hand or mechanically passed into the trench. The latest state and federal safety regulations should be understood and observed. If slings are necessary use only canvas straps, do not use cable or chain slings. A backhoe or boom truck provide an excellent way of lowering the pipe into the trench.

BEDDING: Bedding material should be sand or other materials free of sharp objects, heavy clods, boulders or frozen lumps as specified by the Design Engineer. The approved bedding should be used 6" under, around, and over the pipe. Utilize good practices that apply to buried pressure piping.

ASSEMBLY:

1. Check to make sure rings are in coupling grooves and make certain they are faced properly and completely seated.
2. Check the pipe ends to be sure it is clean, and wipe with a clean, dry rag if necessary.
3. Dig a slight bell hole to keep the joint area clean and free of loose soil during assembly.
4. Lubricate the pipe ends - soap lubricant supplied by Thermal Pipe Systems, Inc. should be applied to the entire outside circumference of the pipe back to the end seal.
5. Start the coupling on by hand, and then holding it straight push the coupling home against the pipe casing using a bar and block. In larger sizes a come-along may be used.

TESTING: All carrier pipe joints shall be tested in accordance with the contract specifications. If no test is specified, it should consist of a hydrostatic test of 150 psi or 1 ½ times working pressure, which ever is greater, for a period of two hours.

CLOSURE OF JOINTS: After completion of testing, apply the factory supplied Casing-Tite Seal circumferentially around the seam between the coupling and pipe casings. Overlap seal 3 inches.

BACKFILLING: Backfilling of trenches shall progress as rapidly as construction, testing, and acceptance of work permits. Uniformly compact and grade bottom of trenches. After installation of pipe and bedding material, backfill as follows: Place initial backfill in layers to a depth of 12" over the top of the initial bedding. Compact the material to a density equivalent to the surrounding undisturbed soil or to 90% of maximum density (ASTM D1557, Method D). For trenches excavated in roads, streets, or located under structures, place backfill in 6" layers to top of trench and compact each layer to at least 95% maximum density (ASTM D1557, Method D).

FLANGED JOINTS: Flanged joints shall be faced true, provided with gaskets and made perfectly square and tight.

FIELD CUTTING PIPE TO A SPECIFIC LENGTH

Determine the exact length of carrier pipe needed. Mark the casing at this point. Measure back 6" on both sides and mark the casing at these points using a wrap-around.

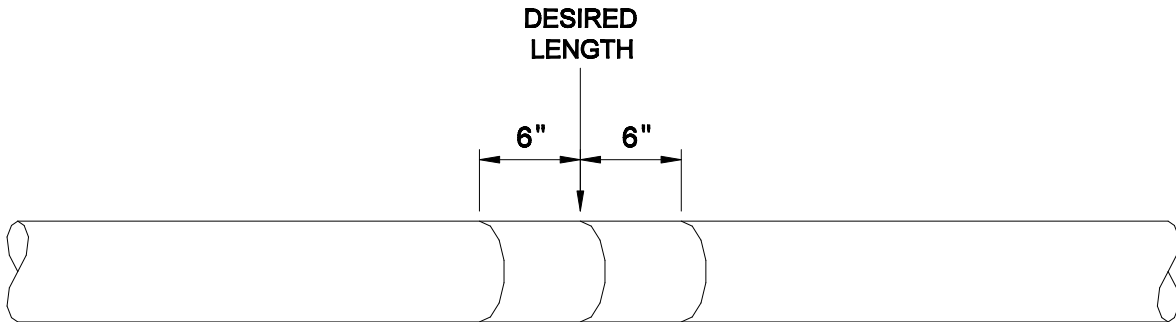

Use a carpenters handsaw or a PVC saw to cut the PVC or HDPE casing. Be careful not to damage the FRP carrier pipe during this cutting operation. Remove the casing and cut off the insulation. See illustration below.

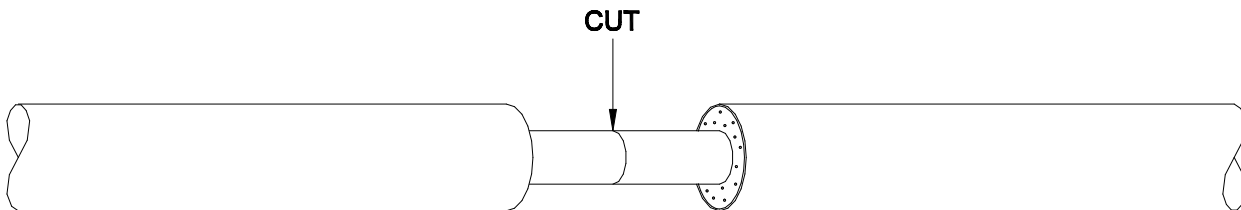

Mark and cut the FRP pipe at the desired length using a fine-toothed hacksaw. Make sure cut is square. If a FRP fitting is to be installed at this point, taper the cut ends using the tapering tool. Using a utility knife, remove the insulation between the casing and the carrier pipe one inch in from the face of the casing as shown below. Insert the rubber end seal between the casing and the carrier pipe using the handle of a hammer or screwdriver to push the seal all the way. Silicone caulking may be used in lieu of the rubber end seal.

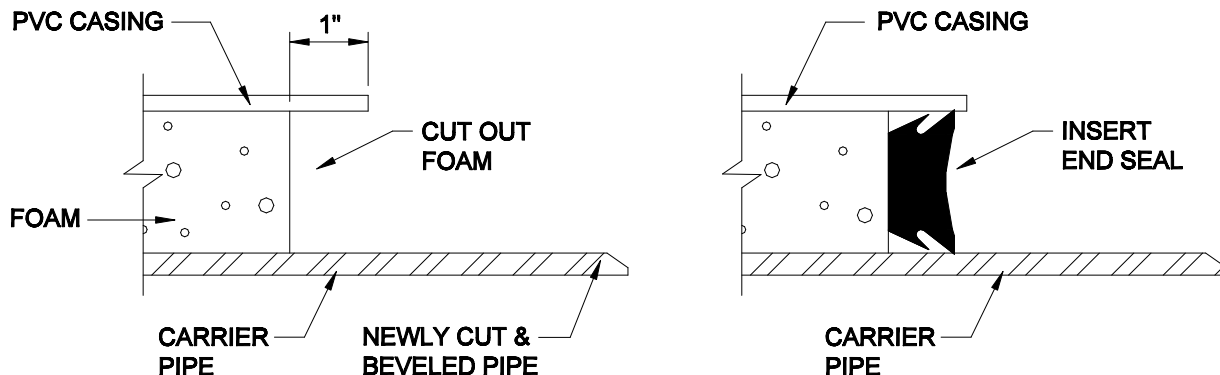

INSTALLING RTRP FITTINGS (IF USING ADHESIVE) :

1. Lightly sand both the bell of the fitting and spigot of pipe with emery cloth. All surfaces must be clean and dry.
2. Pre-warm bonding surfaces after cleaning.
3. Use epoxy adhesive supplied for joining the pipe and fittings. When assembly is ready to be made, add the contents of the small container (hardener) to the large container (resin) and stir thoroughly until a uniform consistency is reached. Rubber gloves should be used when handling adhesive components & cleaner.
4. With the brush supplied, apply a thin layer of adhesive to the tapered surface on the spigot end of the pipe and to the bell of the fitting.
5. Without delay, insert the spigot slowly into the bell using a twisting motion until the fitting locks. Hold for 30 seconds to allow flow of adhesive.
6. Place the heating blanket of fitting and cure for 1 1/2 hours for Mil Spec adhesive installed when ambient air temperatures are less than 70°F. When ambient air temperatures are above 70°F, and for all other adhesives, cure for 30 minutes.

Mechanical force such as a rubber hammer and block must be used to insure proper locking of the joints in sizes 2"-6". In sizes 8"-12" a come-along must be used to insure a proper locking of the joint. A properly assembled joint will show a small bead of adhesive around the entire circumference of the joint.

THRUST BLOCKS: Thrust blocks must be installed wherever the pipeline changes direction or size as at tees, elbows and reducers or at any point that develops thrust such as at a valve or similar equipment. The above situations may occur either where the fittings etc., are directly buried in the soil, or are in a manhole.

Thrust blocks must be designed for maximum anticipated operating or test pressure. If it is anticipated that pressures higher than normal operating pressures will be used at some later date, thrust blocks to accommodate such pressures should be installed initially. Size and type of thrust blocks depend on pressure, pipe size, and the type of soil. This information shall be supplied by the Design Engineer. Where a thrust block serves more than one line, the block must be designed to resist the sum of the thrusts of all the lines involved. Thrust

blocks should be poured on and against undisturbed soil or soil tamped to 95% proctor density.

Thrust blocks shall be installed using concrete having a compressive strength of 3,000 psi minimum ultimate 28 days compressive strength, air entrained, with water reducing admixture. Where the soil bearing value is less than 1,000 pounds per square foot, Thermal Pipe Systems, Inc. will make the necessary calculations and recommendations as to how the fitting should be thrust. Where special thrust provisions are needed, Thermal Pipe Systems, Inc. will recommend the necessary design. The table below gives the thrust load at any fitting in lbs. at 100 psi* pressure.

Size (in.)	90° Elbow	45° Elbow	Tee
2	510	276	361
3	1,187	642	839
4	2,025	1,096	1,432
6	4,458	2,413	3,152
8	7,763	4,201	5,489
10	11,922	6,452	8,430
12	16,750	9,065	11,844

*For pressure other than 100 psi increase loads proportionately (example: for 150 psi multiply by 1.5; for 200 psi multiply by 2.0: etc.)

NOTE: Dead End and Anchor loads are equal to TEE shown above.

The approximate safe bearing loads of various soils given in the following table are for horizontal thrusts when the depth of cover over the top of the pipe exceeds two feet. These loads are estimates only. Actual soil & safe bearing loads should be determined by the Design Engineer.

SOIL	SAFE BEARING LOAD lbs./sq. ft.
Muck, Peat etc.*	0
Soft Clay	1,000
Sand	2,000
Sand & Gravel	3,000
Sand & Gravel Cemented with Clay	4,000
Hard Shale	10,000

*All thrusts are resisted by piles or tie rods to solid foundations, or by removal of muck or peat and replacement with ballast of sufficient stability.

START UP PROCEDURE: Start up procedure shall conform to generally accepted practices and be done in a workman-like manner. The water can be introduced from the lines in the service directly through valved connections, or by temporary connections to taps made in the new line. If possible, all such connections should be made at the lowest point in the line to avoid air entrapment. All valves and other control points in the line that are open as the line filling begins should be closed gradually to avoid the possibility of water hammer.

MANUFACTURERS WRITTEN CERTIFICATION: After testing and prior to start-up of the system, the manufacturer must certify in writing that the system was installed per the manufacturers installation instructions.

